

Capacitance Diaphragm Gauge





CDG025D-X3 4-20 mA Current Loop



Operating Manual
Incl. EU Declaration of Conformity

Product Identification

In all communications with INFICON, please specify the information given on the product nameplate. For convenient reference copy that information into the space provided below.

INFICON AG, LI-9496 Balzers		 
Model:.....		
PN:.....		 
SN:.....		
..... VDC; W		 3103457

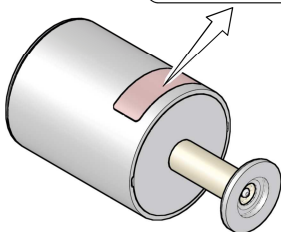

Validity

This document applies to products of the CDG025D-X3 4-20 mA Current Loop series.

Part numbers of standard products are indicated below. OEM products have other part numbers and different parameter settings as defined in the corresponding ordering information.

3CB1-xxx-01E0

Flange	1 ⇒ DN 16 ISO-KF
	3 ⇒ DN 16 CF-R
Unit	9 ⇒ ½" tube
	E ⇒ 8VCR female
	5 ⇒ Torr (x 133 Pa; x 1.3 mbar)
Measurement range (F.S.)	6 ⇒ mbar (x 100 Pa)
	3 ⇒ 0.1
	4 ⇒ 0.25
	5 ⇒ 0.5
	6 ⇒ 1
	7 ⇒ 2
	8 ⇒ 5
	9 ⇒ 10
	A ⇒ 20
	B ⇒ 50
	C ⇒ 100
	D ⇒ 200
	E ⇒ 500
	F ⇒ 1000 (Torr only)
G ⇒ 1100 (mbar only)	

The part number (PN) can be taken from the product nameplate. We reserve the right to make technical changes without prior notice.

Intended Use

The Capacitance Diaphragm Gauges of the CDG025D-X3 4-20 mA Current Loop series are intended for absolute pressure measurement of gases in their respective pressure ranges (→  3). They are clean room compliant and double protected against contamination.

The gauges belong to the SKY[®] Smart Sensors family and can be operated in connection with an appropriate 4 ... 20 mA measuring unit.

Function

The Capacitance Diaphragm Gauge consists of a capacitive sensor element made of aluminum oxide ceramics and electronics which convert the capacitance into a DC current output signal.

The output signal is linear to the measured pressure and independent of the gas type.

Trademarks

SKY[®] INFICON GmbH
VCR[®] Swagelok Marketing Co.

Patents



EP 1070239 B1, 1040333 B1
US Patents 6528008, 6591687, 7107855, 7140085

Scope of Delivery

- 1× Gauge in clean room packaging
- 1× Pin for adjusting settings via buttons
- 1× Calibration Test Report
- 1× Operating Manual (German and / or English)

Contents

Product Identification	2
Validity	3
Intended Use	4
Function	4
Trademarks	4
Patents	4
Scope of Delivery	4
1 Safety	6
1.1 Symbols Used	6
1.2 Personnel Qualifications	6
1.3 General Safety Instructions	7
1.4 Liability and Warranty	7
2 Technical Data	8
3 Installation	12
3.1 Vacuum Connection	12
3.2 Electrical Connection	15
4 Operation	17
4.1 Status Indicator	17
4.2 Zeroing the Gauge	18
4.2.1 <ZERO> Adjustment	19
4.3 Activating the Factory Setting (Factory Reset)	22
5 Deinstallation	23
6 Maintenance, Repair	24
7 Returning the Product	25
8 Disposal	25
ETL Certification	26
EU Declaration of Conformity	27

For cross-references within this document, the symbol (→  XY) is used, for cross-references to further documents, listed under "Further Information", the symbol (→  [Z]).

1 Safety

1.1 Symbols Used



Information on preventing any kind of physical injury.



Information on preventing extensive equipment and environmental damage.



Information on correct handling or use. Disregard can lead to malfunctions or minor equipment damage.



Consultation of operating manual required (symbol printed on the product nameplate)



Notice

<.....> Labelling

1.2 Personnel Qualifications



All work described in this document may only be carried out by persons who have suitable technical training and the necessary experience or who have been instructed by the end-user of the product.

1.3 General Safety Instructions

- Adhere to the applicable regulations and take the necessary precautions for the process media used.
Consider possible reactions with the product materials.
- Adhere to the applicable regulations and take the necessary precautions for all work you are going to do and consider the safety instructions in this document.
- Before beginning to work, find out whether any vacuum components are contaminated. Adhere to the relevant regulations and take the necessary precautions when handling contaminated parts.

Communicate the safety instructions to all other users.

1.4 Liability and Warranty

INFICON assumes no liability and the warranty becomes null and void if the end-user or third parties

- disregard the information in this document
- use the product in a non-conforming manner
- make any kind of interventions (modifications, alterations etc.) on the product
- use the product with accessories not listed in the product documentation.

The end-user assumes the responsibility in conjunction with the process media used.

Gauge failures due to contamination are not covered by the warranty.

2 Technical Data

Measurement range	→ "Validity"
Accuracy ¹⁾	
≥1 Torr/mbar (F.S.)	0.20% of reading
0.25 Torr/mbar (F.S.)	0.25% of reading
0.1 Torr/mbar (F.S.)	0.50% of reading
Temperature effect on zero	
≥10 Torr/mbar (F.S.)	0.0050% F.S./ °C
1 / 2 Torr/mbar (F.S.)	0.015% F.S./ °C
0.1 / 0.25 Torr/mbar (F.S.)	0.020% F.S./ °C
Temperature effect on span	
≥1 Torr/mbar (F.S.)	0.01% of reading / °C
0.1 / 0.25 Torr/mbar (F.S.)	0.03% of reading / °C
Resolution	0.003% F.S.
Gas type dependence	none
<hr/>	
Output signal analog (measuring signal)	2-wire, current loop
Signal range	3.8 ... 20.2 mA
Measuring range (zero ... F.S.)	4.0 ... 20.0 mA
Relationship current-pressure	linear
Loaded impedance R _L	typical 500 Ω ±1% at 24 ±3 V (dc) ²⁾
	absolute 309 ... 654 Ω at 24 V ²⁾
	160 ... 505 Ω at 21 V ²⁾
	457 ... 802 Ω at 27 V ²⁾
Step response time	≤100 ms
<hr/>	

¹⁾ Non-linearity, hysteresis, repeatability in the calibrated range at 25 °C ambient operating temperature without temperature effects after operation of 2 h.

²⁾ Supply voltage at the gauge.

Remote zero input	digital input, floating contact
High level	+19 ... +27 V (dc) / ≤ 8 mA
Low level (open)	<2 V
Remote Zero function	
High level (pulse >1 s ... <5 s)	auto zero adjust
Low level	measurement operation

Supply



DANGER

The gauge may only be connected to power supplies, instruments or control devices that conform to the requirements of a grounded protective extra-low voltage (PELV) and limited power source (LPS), Class 2.

Supply voltage at the gauge	+24 \pm 3 V (dc)
The gauge is protected against reverse polarity of the supply voltage.	

Electrical connection	9-pin D-Sub, male
Sensor cable	
without remote zero	2-pin plus shielding, twisted
with remote zero	4-pin plus shielding, twisted
Cable length / cross-section	
<25 m	0.14 mm ² / conductor
25 ... 50 m	0.25 mm ² / conductor
>50 ... 300 m	0.50 mm ² / conductor

For longer cables, larger conductor cross-sections are required ($R_{\text{cable}} \leq 1.0 \Omega$).

Grounding concept	
Vacuum flange - loop common	potential isolated

Materials exposed to vacuum

Flange, tube stainless steel AISI 316L
 Sensor and diaphragm ceramics ($\text{Al}_2\text{O}_3 \geq 99.5\%$)

Internal volume $\leq 3.6 \text{ cm}^3$

Admissible pressure (absolute)

$\geq 200 \text{ Torr/mbar (F.S.)}$ 4 bar | 400 kPa
 $1 \dots 100 \text{ Torr/mbar (F.S.)}$ 2.6 bar | 260 kPa
 $0.1 / 0.25 \text{ Torr/mbar (F.S.)}$ 1.3 bar | 130 kPa

Bursting pressure (absolute) 5 bar | 500 kPa

Admissible temperatures

Storage $-20 \text{ }^\circ\text{C} \dots +65 \text{ }^\circ\text{C}$
 Operation $+5 \text{ }^\circ\text{C} \dots +60 \text{ }^\circ\text{C}$
 Bakeout (not in operation) $\leq 110 \text{ }^\circ\text{C}$ at the flange

Relative humidity $\leq 80\%$ at temperatures
 $\leq +31 \text{ }^\circ\text{C}$ decreasing to 50%
 at $+40 \text{ }^\circ\text{C}$

Use indoors only, altitude up to
 2000 m NN

Degree of protection IP 30

Dimensions [mm (inch)]

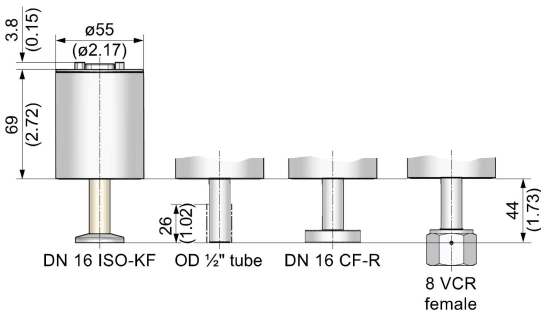

Weight

$\leq 370 \text{ g}$

Analog Measuring Signal vs. Pressure

Pressure p

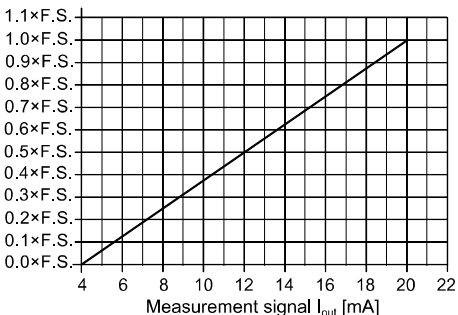

$$p = [(I_{out} - 4 \text{ mA}) / 16 \text{ mA}] \times p \text{ (F.S.)}$$

Conversion Torr \leftrightarrow Pascal

	Torr	mbar ³⁾	Pa ³⁾
c	1.00	1013.25 / 760 = 1.3332...	101325 / 760 = 133.3224...

Example: Gauge with 10 Torr F.S.
Measuring signal $I_{out} = 12 \text{ mA}$

$$p = [(12 \text{ mA} - 4 \text{ mA}) / 16 \text{ mA}] \times 10 \text{ Torr} \\ = 0.5 \times 10 \text{ Torr} = \mathbf{5 \text{ Torr}}$$

³⁾ Source: NPL (National Physical Laboratory)
Guide to the Measurement of Pressure and Vacuum,
ISBN 0904457x / 1998

3 Installation



WARNING



WARNING: fragile components

The ceramic sensor may be damaged by impacts.

Do not drop the product and prevent shocks and impacts.

3.1 Vacuum Connection



DANGER



DANGER: overpressure in the vacuum system
>1 bar

Injury caused by released parts and harm caused by escaping process gases can result if clamps are opened while the vacuum system is pressurized.

Do not open any clamps while the vacuum system is pressurized. Use the type clamps which are suited to overpressure.



DANGER



DANGER: overpressure in the vacuum system
>2.5 bar

KF flange connections with elastomer seals (e.g. O-rings) cannot withstand such pressures. Process media can thus leak and possibly damage your health.

Use O-rings provided with an outer centering ring.



DANGER



DANGER: protective ground

Products that are not correctly connected to ground can be extremely hazardous in the event of a fault.

Electrically connect the gauge to the grounded vacuum chamber. This connection must conform to the requirements of a protective connection according to EN 61010:

- For gauges with a KF flange, use a conductive metallic clamping ring.



Caution



Caution: vacuum component

Dirt and damages impair the function of the vacuum component.

When handling vacuum components, take appropriate measures to ensure cleanliness and prevent damages.



Caution



Caution: dirt sensitive area

Touching the product or parts thereof with bare hands increases the desorption rate.

Always wear clean, lint-free gloves and use clean tools when working in this area.



Mount the gauge so that no vibrations occur. The gauge may be mounted in any orientation. To keep condensates and particles from getting into the measuring chamber preferably choose a horizontal to upright position and possibly use a seal with a centering ring and filter. If adjustment should be possible after the gauge has been installed, be sure to install it so that the buttons can be accessed with a pin (→ 18).

Remove the protective lid and connect the product to the vacuum system.

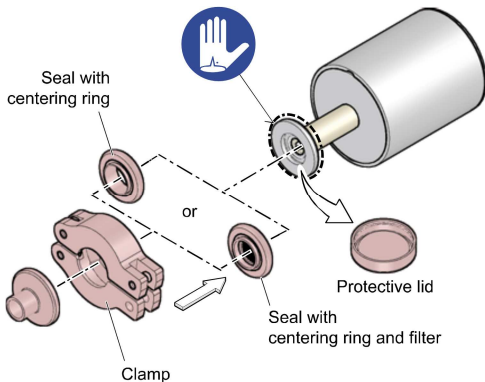



Keep the protective lid.

3.2 Electrical Connection



Make sure the vacuum connection is properly made (→  12).

DANGER



The gauge may only be connected to power supplies, instruments or control devices that conform to the requirements of a grounded protective extra-low voltage (PELV) and limited power source (LPS), Class 2.



Ground loops, differences of potential, or EMC problems may affect the measurement signal. For optimum signal quality observe the following notes:

- Typically connect the cable shield to ground on gauge side via the chassis ground.
- Depending on the situation, following measures can cause better signal quality:
 - connect the cable shield to ground on power supply side, or
 - connect the cable shield to ground on both sides.

If no sensor cable is available, make one according to the following diagram. Connect the cable.

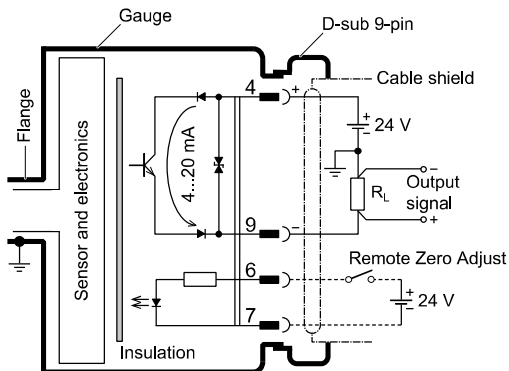

Electrical Connection

- Pin 4 Positive Excitation
- Pin 6 Remote Zero Supply
- Pin 7 Remote Zero Common
- Pin 9 Negative Excitation

- Pin 1, 2, 3, 5, 8: n.c.

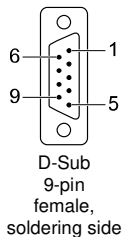

4 Operation

Put the gauge into operation.

Warm-up time

- for general purpose reading (within specifications) >¼ hour
- for zero adjustment and precision measurement >2 hours

4.1 Status Indicator

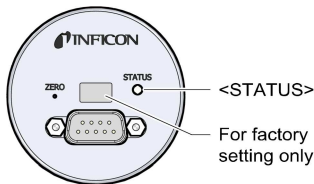

<STATUS> indicator	Meaning
Off	no supply voltage
Lit solid green	measurement mode
Blinking green	zero-adjust mode or warning, over/underrange
Blinking red	zero-adjust error
Lit solid red	error

4.2 Zeroing the Gauge

The gauge is factory calibrated while "standing upright" (→ "Calibration Test Report").



We recommend performing a zero adjustment, when the gauge is operated for the first time.

Due to long time operation or contamination, a zero drift could occur and zero adjustment may become necessary.

For adjusting the zero, operate the gauge under the same constant ambient conditions and in the same mounting orientation as normally.

The output signal (measuring signal) is depending on the mounting orientation. The signal difference between the vertical and horizontal mounting orientation is:

F.S.	$\Delta p / 90^\circ$
1000 Torr	$\approx 0.02\%$ F.S.
100 Torr	$\approx 0.1\%$ F.S.
10 Torr	$\approx 0.5\%$ F.S.
1 Torr	$\approx 3\%$ F.S.
0.1 Torr	$\approx 18\%$ F.S.

4.2.1 <ZERO> Adjustment



The zero can be adjusted via

- the <ZERO> button on the gauge,
- the digital input "Remote Zero" (briefly apply the supply voltage to pin 6: pulse →  9).

1

Evacuate the gauge to a pressure according to the table below:

F.S.	Recommended final pressure for zero adjustment		
1100 mbar	–	$<6.7 \times 10^0$ Pa	$<6.7 \times 10^{-2}$ mbar
1000 Torr	$<5 \times 10^{-2}$ Torr	$<6.7 \times 10^0$ Pa	–
500 Torr/mbar	$<2.5 \times 10^{-2}$ Torr	$<3.3 \times 10^0$ Pa	$<3.3 \times 10^{-2}$ mbar
200 Torr/mbar	$<10^{-2}$ Torr	$<1.3 \times 10^0$ Pa	$<1.3 \times 10^{-2}$ mbar
100 Torr/mbar	$<5 \times 10^{-3}$ Torr	$<6.7 \times 10^{-1}$ Pa	$<6.7 \times 10^{-3}$ mbar
50 Torr/mbar	$<2.5 \times 10^{-3}$ Torr	$<3.3 \times 10^{-1}$ Pa	$<3.3 \times 10^{-3}$ mbar
20 Torr/mbar	$<10^{-3}$ Torr	$<1.3 \times 10^{-1}$ Pa	$<1.3 \times 10^{-3}$ mbar
10 Torr/mbar	$<5 \times 10^{-4}$ Torr	$<6.7 \times 10^{-2}$ Pa	$<6.7 \times 10^{-4}$ mbar
5 Torr/mbar	$<2.5 \times 10^{-4}$ Torr	$<3.3 \times 10^{-2}$ Pa	$<3.3 \times 10^{-4}$ mbar
2 Torr/mbar	$<10^{-4}$ Torr	$<1.3 \times 10^{-2}$ Pa	$<1.3 \times 10^{-4}$ mbar
1 Torr/mbar	$<5 \times 10^{-5}$ Torr	$<6.7 \times 10^{-3}$ Pa	$<6.7 \times 10^{-5}$ mbar
0.5 Torr/mbar	$<2.5 \times 10^{-5}$ Torr	$<3.3 \times 10^{-3}$ Pa	$<3.3 \times 10^{-5}$ mbar
0.25 Torr/mbar	$<10^{-5}$ Torr	$<1.3 \times 10^{-3}$ Pa	$<1.3 \times 10^{-5}$ mbar
0.1 Torr/mbar	$<5 \times 10^{-6}$ Torr	$<6.7 \times 10^{-4}$ Pa	$<6.7 \times 10^{-6}$ mbar

If the final pressure in the gauge is too high for zero adjustment ($>25\%$ of the F.S.), the zero cannot be reached and the <STATUS> indicator flashes.

2

Operate the gauge for at least 2 hours (until the signal is stable).

- 3** Briefly (>1 s) press the <ZERO> button with a pin (max. $\varnothing 1.1$ mm), or ...

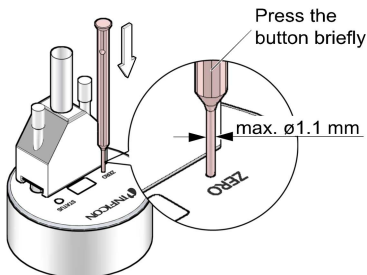

... briefly apply the supply voltage to pin 6 (Remote Zero, (→ diagram 16, pulse → 9).

The zero adjustment runs automatically. The <STATUS> indicator flashes until the adjustment (duration ≈ 8 s) is completed.



After zero adjustment the gauge automatically returns to measurement mode.

The <STATUS> indicator flashes if

- the signal output is negative (< 4 mA) when the final pressure has been attained
- the zero adjustment has failed.

4.2.2 <ZERO> Adjustment with Ramp Function

The ramp function allows to adjust the zero at a known reference pressure within the measurement range of the gauge.

It also permits to adjust an offset of the characteristic curve in order to compensate for the offset of the measuring system.

The offset should not exceed 1.5% of the F.S. (4 ... 4.2 mA). At a higher positive offset, the upper limit of the measurement range is exceeded.

- 1** Operate the gauge for at least 15 minutes (until the signal is stable).
- 2** Push the <ZERO> button with a pin (max. $\varnothing 1.1$ mm) and keep it depressed. The <STATUS> indicator starts flashing. After 5 s, the zero adjustment value, starting at the current output value, keeps continually changing (ramp) until the button is released or until the setting limit (max. 25% F.S.) is reached. The corresponding output signal is delayed by about 1 s.

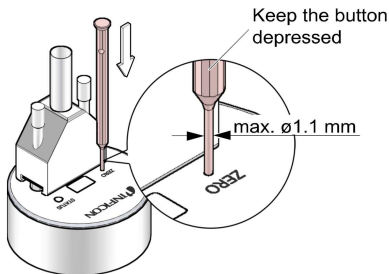

- Change of direction (inverse ramp): Release the button. Press and keep it depressed again within 3 ... 5 s (the flashing frequency of the <STATUS> indicator changes briefly).
- Fine adjustment: Release the button. Briefly press it again within 0 ... 3 s. The zero adjustment value changes by one unit (push <ZERO> button in intervals of 1 s).



If the <ZERO> button is released for more than 5 s, the gauge returns to the measurement mode.

The <STATUS> indicator flashes if the signal output is negative (<4 mA).

4.3 Activating the Factory Setting (Factory Reset)

All user defined parameters (e.g. zero, filter) are restored to their default values.



Loading of the default parameters is irreversible.

Loading the default parameters:



Put the gauge out of operation.



Keep the <ZERO> button depressed for at least 5 s while the gauge is being put into operation (Power ON).

5 Deinstallation



WARNING



WARNING: fragile components
The ceramic sensor may be damaged by impacts.
Do not drop the product and prevent shocks and impacts.



DANGER



DANGER: contaminated parts
Contaminated parts can be detrimental to health and environment.
Before beginning to work, find out whether any parts are contaminated. Adhere to the relevant regulations and take the necessary precautions when handling contaminated parts.



Caution



Caution: vacuum component
Dirt and damages impair the function of the vacuum component.
When handling vacuum components, take appropriate measures to ensure cleanliness and prevent damages.



Caution



Caution: dirt sensitive area

Touching the product or parts thereof with bare hands increases the desorption rate.

Always wear clean, lint-free gloves and use clean tools when working in this area.

- ❶ Vent the vacuum system.
- ❷ Put the gauge out of operation.
- ❸ Unfasten the lock screws and disconnect the sensor cable.
- ❹ Remove the gauge from the vacuum system and install the protective lid.

6 Maintenance, Repair

Under clean operating conditions, the product requires no maintenance.



Gauge failures due to contamination are not covered by the warranty.

We recommend checking the zero at regular intervals (→  19).

INFICON assumes no liability and the warranty becomes null and void if any repair work is carried out by the end-user or third parties.

7 Returning the Product



WARNING

WARNING: forwarding contaminated products
Contaminated products (e.g. radioactive, toxic, caustic or microbiological hazard) can be detrimental to health and environment.

Products returned to INFICON should preferably be free of harmful substances. Adhere to the forwarding regulations of all involved countries and forwarding companies and enclose a duly completed declaration of contamination (form under www.inficon.com).

Products that are not clearly declared as "free of harmful substances" are decontaminated at the expense of the customer. Products not accompanied by a duly completed declaration of contamination are returned to the sender at his own expense.



8 Disposal



DANGER

DANGER: contaminated parts
Contaminated parts can be detrimental to health and environment.

Before beginning to work, find out whether any parts are contaminated. Adhere to the relevant regulations and take the necessary precautions when handling contaminated parts.

	 WARNING
	<p>WARNING: substances detrimental to the environment</p>
	<p>Products or parts thereof (mechanical and electric components, operating fluids etc.) can be detrimental to the environment.</p> <p>Dispose of such substances in accordance with the relevant local regulations.</p>

Separating the components

After disassembling the product, separate its components according to the following criteria:

- Contaminated components

Contaminated components (radioactive, toxic, caustic or biological hazard etc.) must be decontaminated in accordance with the relevant national regulations, separated according to their materials, and disposed of.
- Other components

Such components must be separated according to their materials and recycled.

ETL Certification



ETL LISTED

The product CDG025D-X3 4-20 mA

- conforms to the UL Standard UL 61010-1
- is certified to the CSA Standard CSA C22.2 # 61010-1

EU Declaration of Conformity



We, INFICON, hereby declare that the equipment mentioned below complies with the provisions of the Directive relating to electromagnetic compatibility 2014/30/EU and the Directive on the restriction of the use of certain hazardous substances in electrical and electronic equipment 2011/65/EU.

Capacitance Diaphragm Gauge

CDG025D-X3 4-20 mA Current Loop

Standards

Harmonized and international/national standards and specifications:

- EN 61000-6-2:2005 (EMC: generic immunity standard)
- EN 61000-6-3:2007 + A1:2011 (EMC: generic emission standard)
- EN 61010-1:2010 (Safety requirements for electrical equipment for measurement, control and laboratory use)
- EN 61326:2013 (EMC requirements for electrical equipment for measurement, control and laboratory use)

Manufacturer / Signatures

INFICON AG, Alte Landstraße 6, LI-9496 Balzers

22 April 2015



Dr. Urs Wälchli
Managing Director

22 April 2015

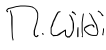

Michael Wildi
Product Manager

Original: German tinb16d1-a (2017-02)



t1 rbt6el-a



LI-9496 Balzers
Liechtenstein
Tel +423 / 388 3111
Fax +423 / 388 3700
reachus@inficon.com

www.inficon.com